

15	4	kom.	Navrtka M16	PT.00.015	
14	28	kom.	Navrtka M10	PT.00.014	
13	10	kom.	Navrtka M8	PT.00.013	
12	4	kom.	Zavrtanj M16x40	PT.00.012	
11	28	kom.	Zavrtanj M10x35	PT.00.011	
10	10	kom.	Zavrtanj M8x20	PT.00.010	
9	1	kom.	Remenica	PT.00.09	
8	1	kom.	Konusna čaura	PT.00.08	
7	1	kom.	Klin 10x8x60	PT.00.07	
6	1	kom.	Gornji poklopac	PT.00.06	
5	2	kom.	Ležajna čaura	PT.00.05	
4	2	kom.	Kuciste lezaja	PT.00.04	
3	2	kom.	Poklopac puza	PT.00.03	
2	1	kom.	Spirala puza fi 250	PT.00.02	
1	1	kom.	Korito puza	PT.00.01	

Poz.	Kol.	Jm.	Naziv	Standard-izabrane karakteristike	Primedba
			Broj komada	1	
			Format	A3	Masa
					Razmera 1:10
			Datum		
			Obradio		
			Stand.		
			Odobrio		
			ZAJEDNICA MAŠINSKIH ŠKOLA		Oznaka
					PT.00.00
St.i	Izmene	Datum	Ime	Izv.pod.	Zamena za

Pužni transporter PT18-1

**ZAJEDNICA
MAŠINSKIH
ŠKOLA**

PT.00.00

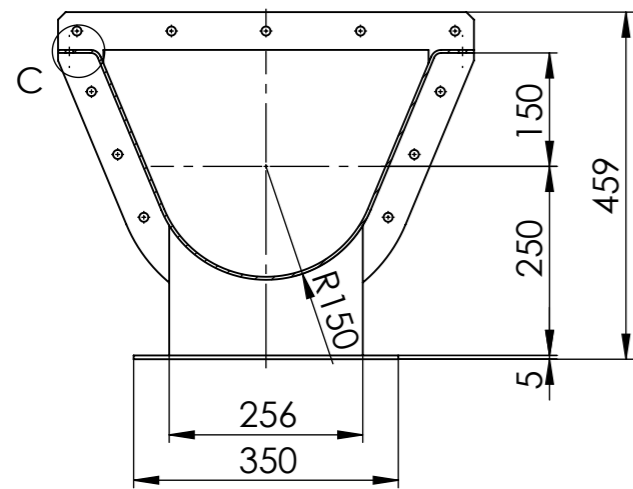

Presek B-B

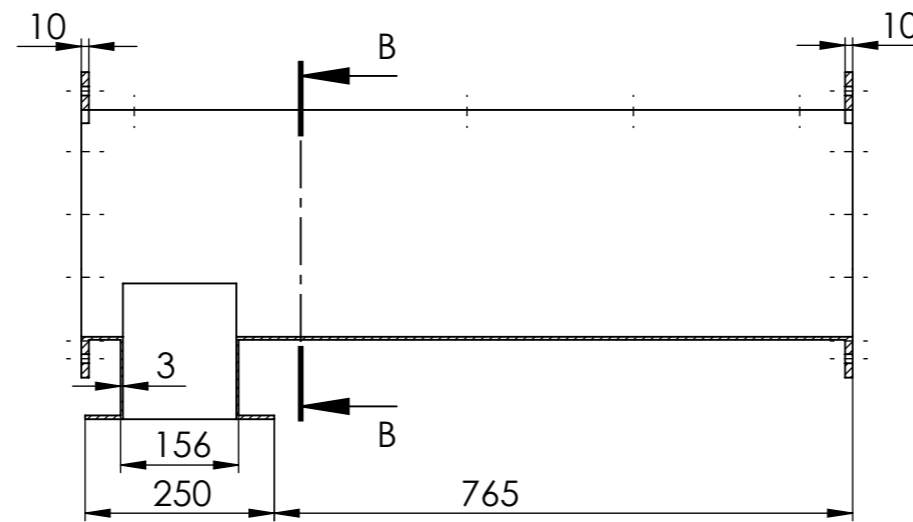

Presek A-A

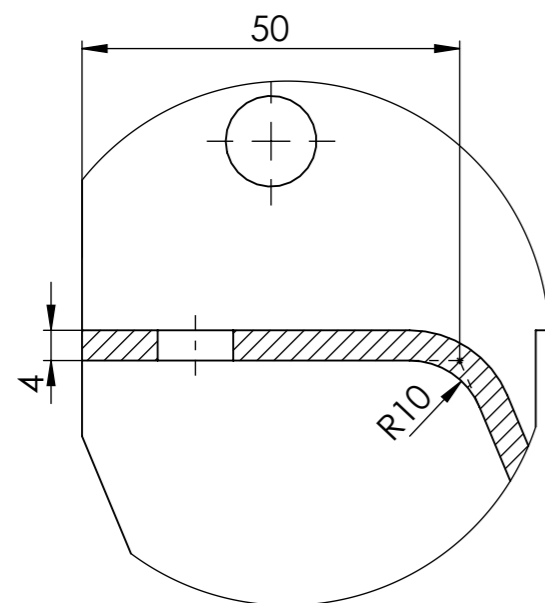
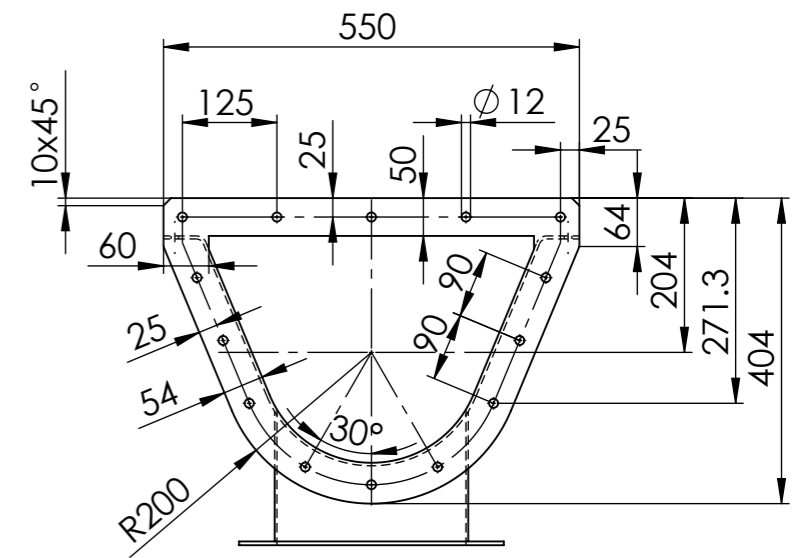

Detalj C
Razmera 1 : 1

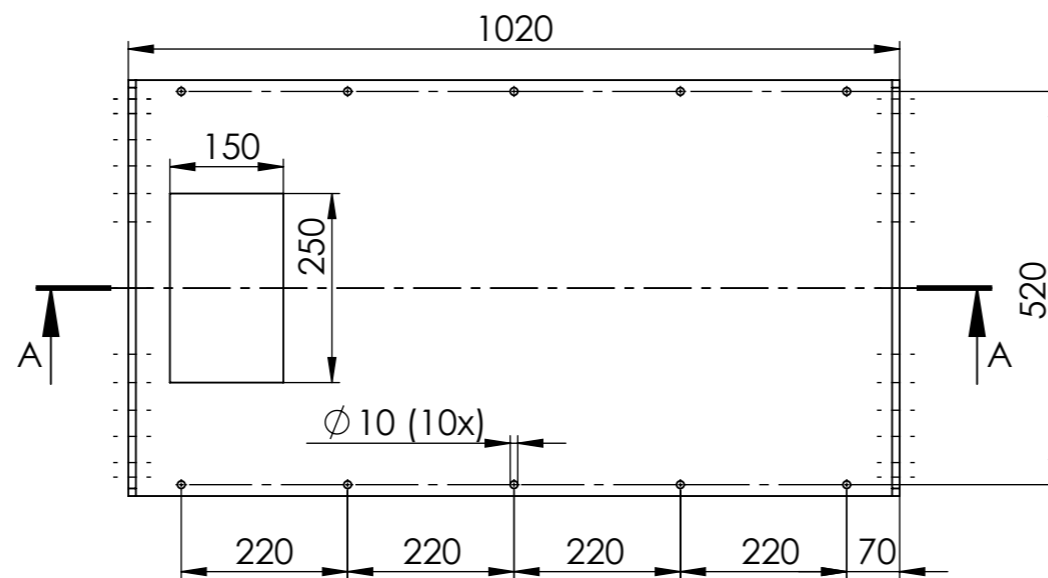

				Broj komada 1		Format A3	Masa	Razmera 1:10						
<table border="1"> <tr> <td>Datum</td> <td></td> </tr> <tr> <td>Obradio</td> <td></td> </tr> <tr> <td>Stand. Odobrio</td> <td></td> </tr> </table>						Datum		Obradio		Stand. Odobrio		Naziv		
Datum														
Obradio														
Stand. Odobrio														
ZAJEDNICA MAŠINSKIH ŠKOLA						Oznaka		List						
						PT.00.01								
St.i	Izmene	Datum	Ime			Izv.pod.	Zamena za							

N11 ✓✓

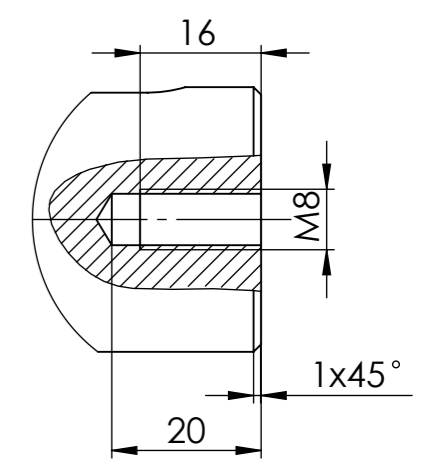
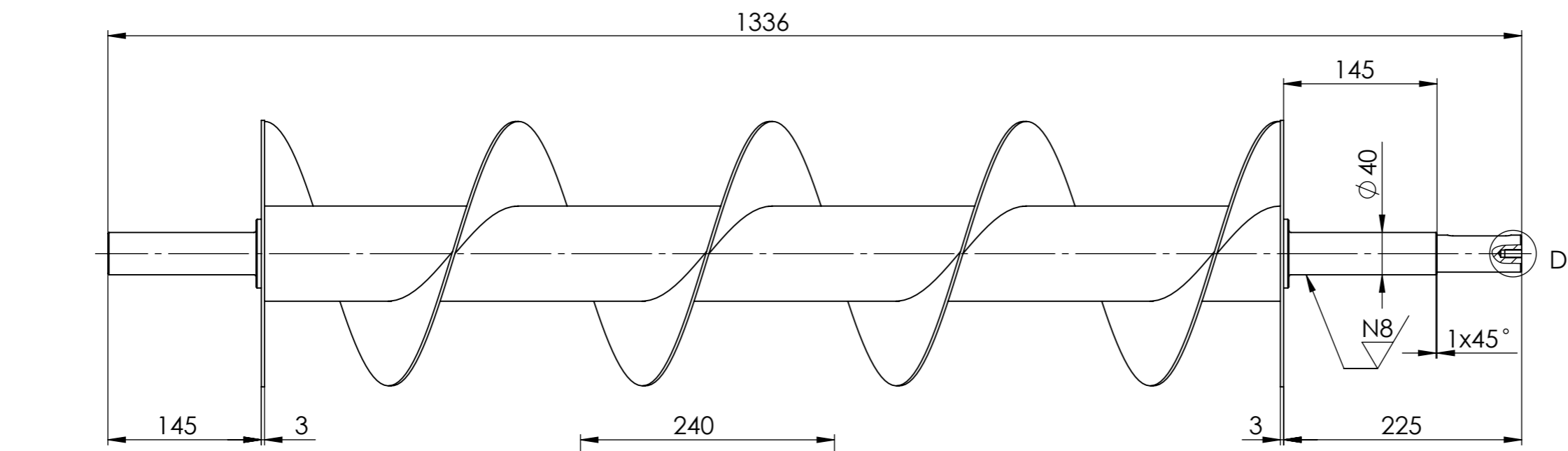

Detalj D
Razmera 1 : 1

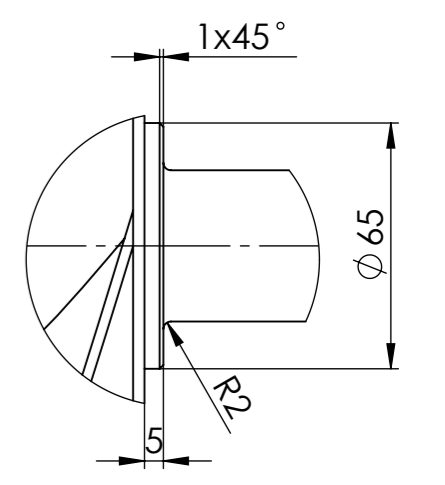
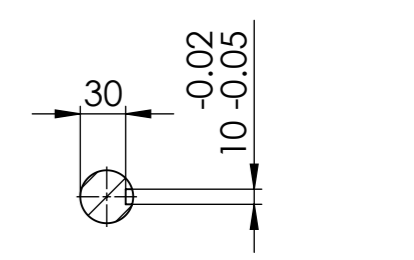
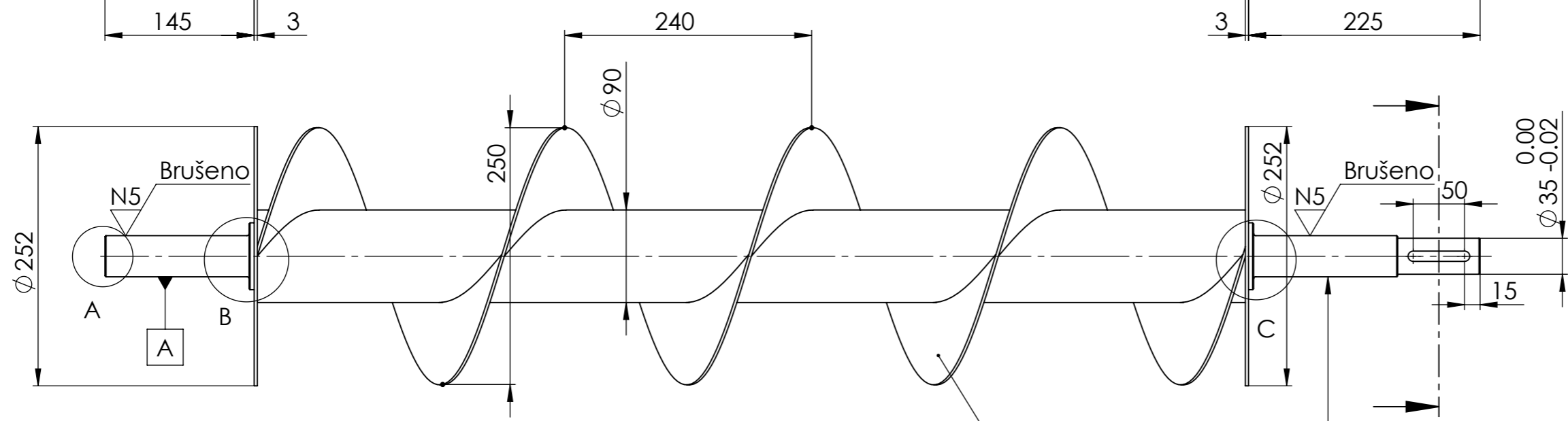

Detalj C
Razmera 1 : 2

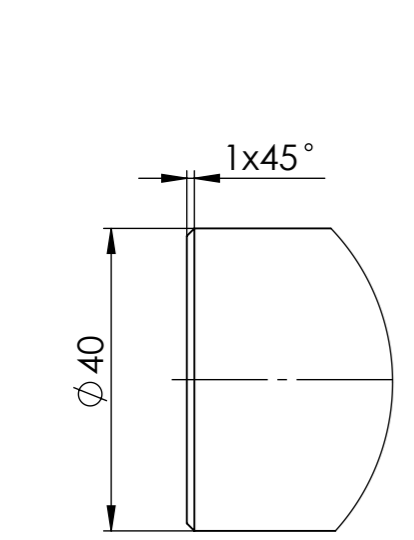

Detalj A
Razmera 1 : 1

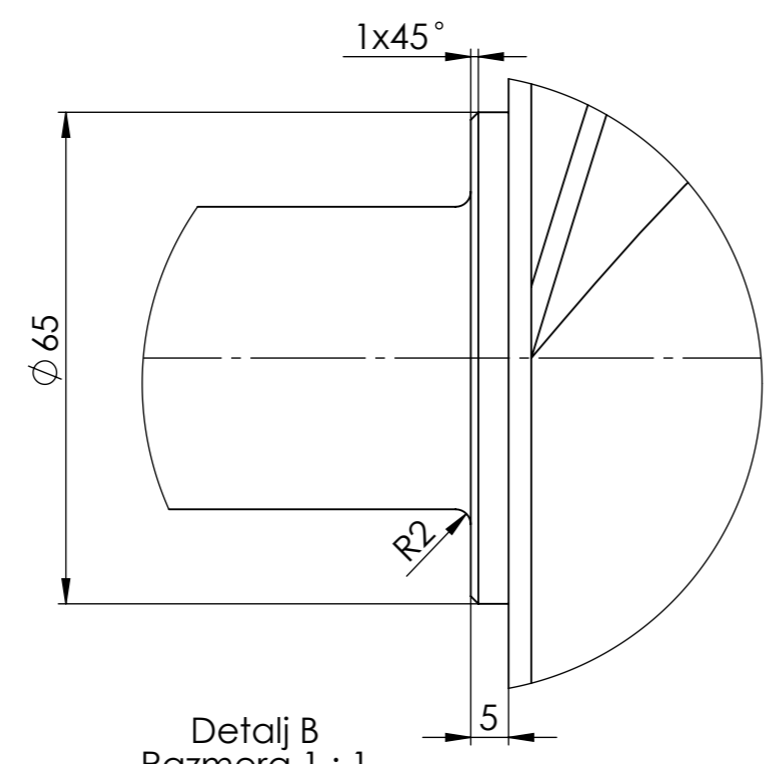

Detalj B
Razmera 1 : 1

Broj komada 1				Format	A3	Masa	Razmera	1:5
Datum Obradio				Naziv Spirala puža				
Stand. Odobrio				Oznaka PT.00.02				
St.i Izmene				List				
Datum Ime				Izv.pod.		Zamena za		
ZAJEDNICA MAŠINSKIH ŠKOLA								

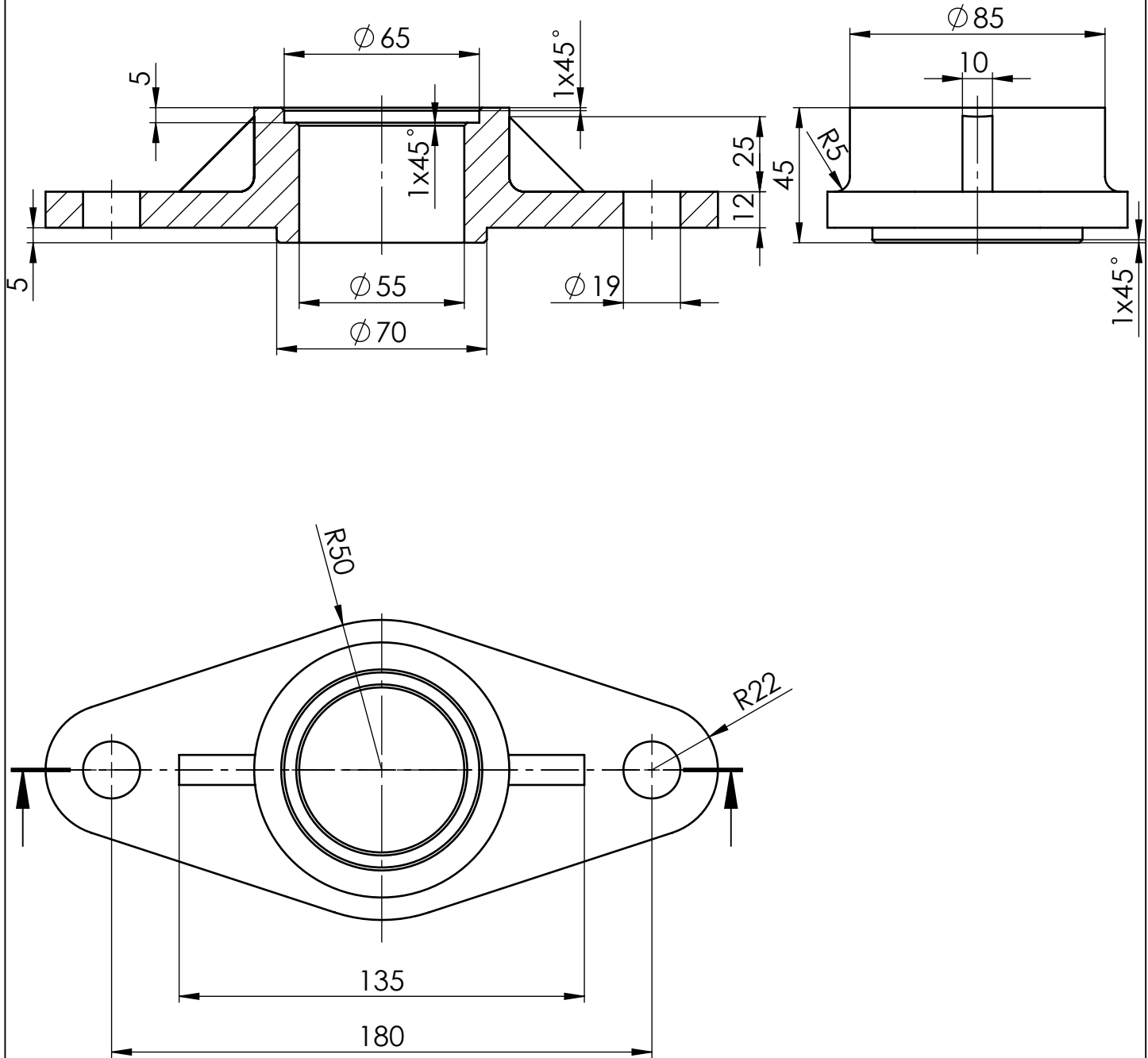

Tolerancije slobodnih mera		Površinska hrapavost		Površinska zaštita									
Materijal				Termička obrada									
		Broj komada 2		Format A4	Razmera 1:2								
<table border="1"> <tr><td>Datum</td><td></td></tr> <tr><td>Obradio</td><td></td></tr> <tr><td>Stand.</td><td></td></tr> <tr><td>Odobrio</td><td></td></tr> </table>				Datum		Obradio		Stand.		Odobrio		Naziv Kućište ležaja	
Datum													
Obradio													
Stand.													
Odobrio													
ZAJEDNICA MAŠINSKIH ŠKOLA				Oznaka PT.00.04 List									
St.i	Izmene	Datum	Ime	Izv.pod.	Zamena za								

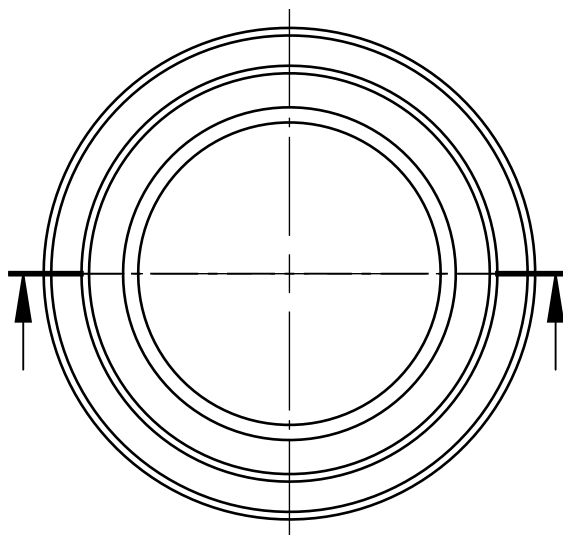
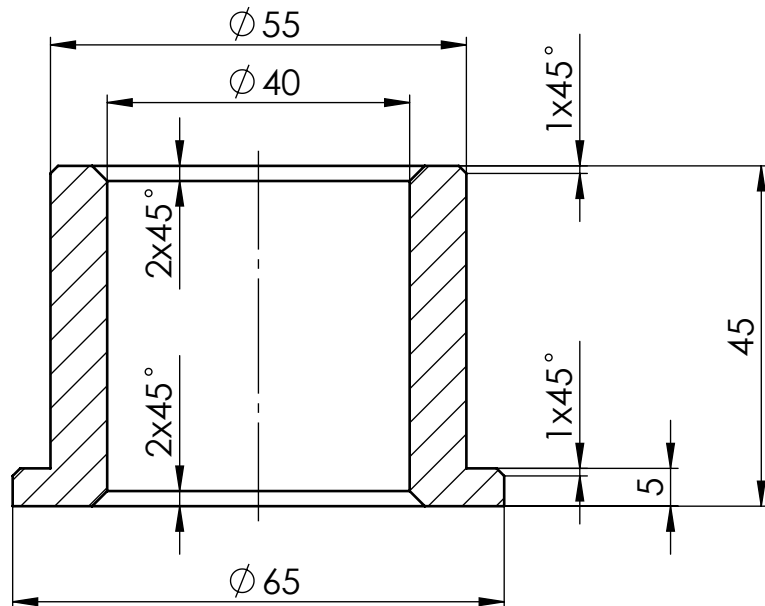

Tolerancije slobodnih mera		Površinska hrapavost		Površinska zaštita	
Materijal				Termička obrada	
		Broj komada 2		Format A4	Razmera 1:1
Datum				Naziv	
Obradio				Ležajna čaura	
Stand.					
Odobrio					
ZAJEDNICA MAŠINSKIH ŠKOLA				Oznaka	List
				PT.00.05	
St.i	Izmene	Datum	Ime	Izv.pod.	Zamena za

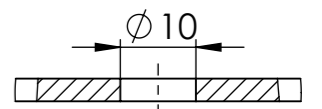
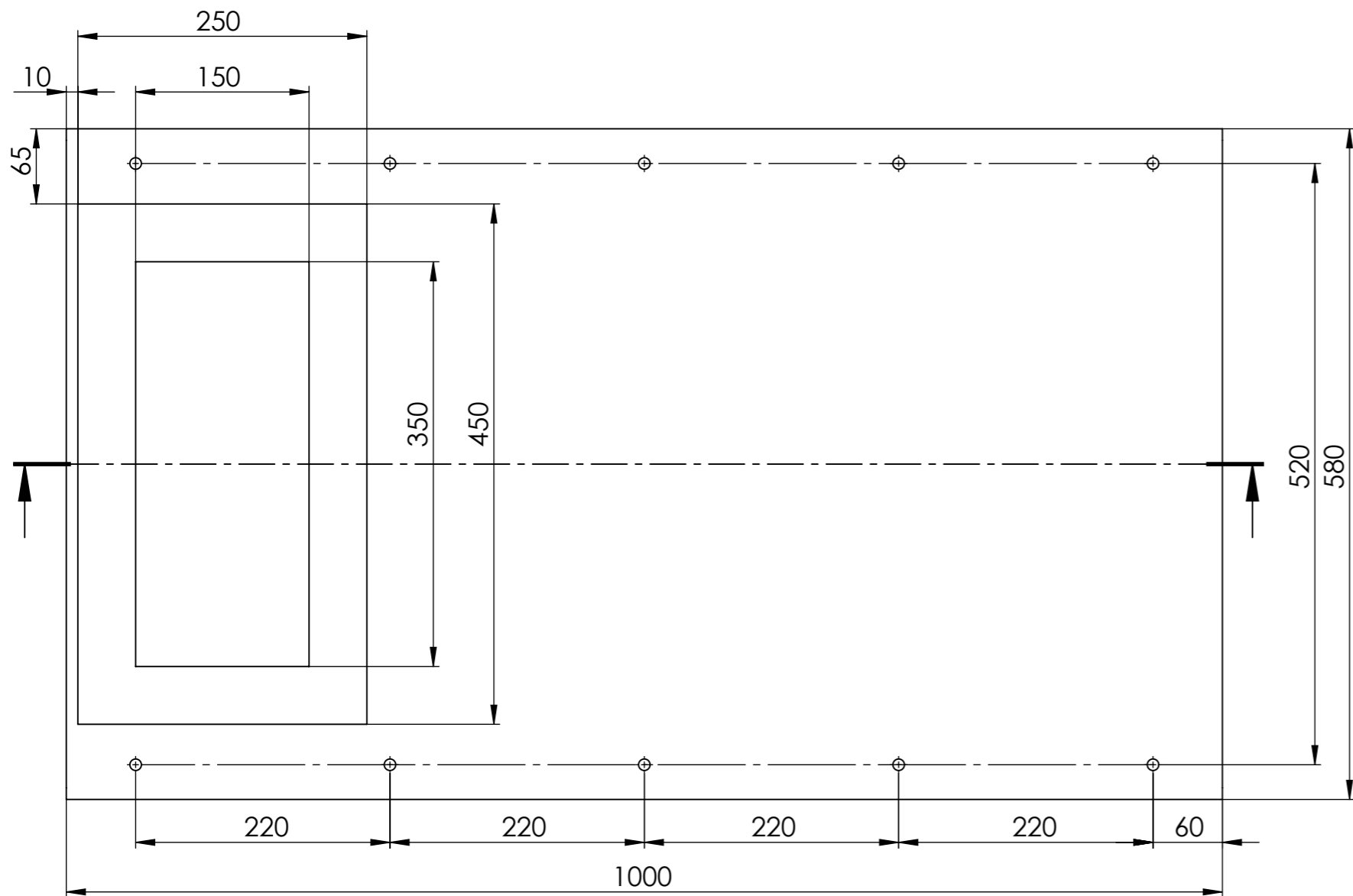
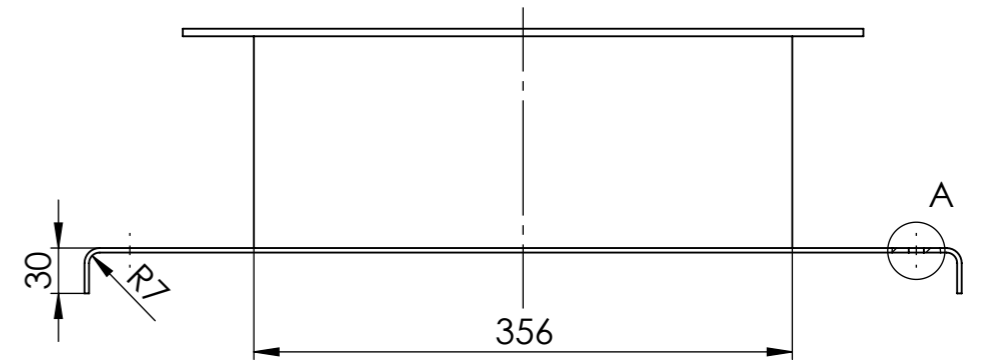
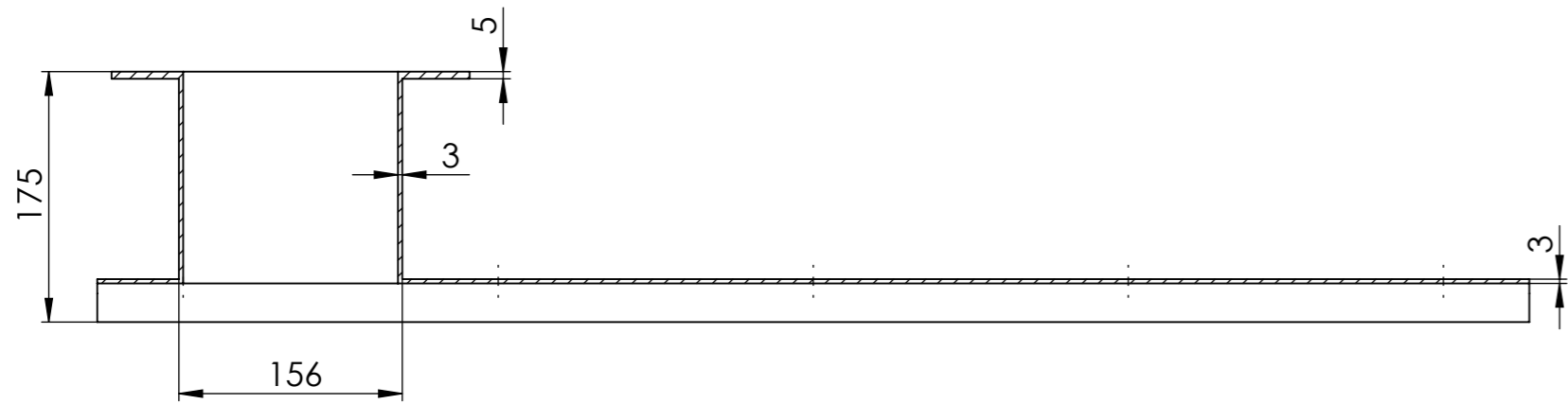

Detalj A
Razmera 1 : 1

				Broj komada 1		Format A3	Masa	Razmera 1:5
				Datum		Naziv <i>Gornji poklopac</i>		
				Obradio				
				Stand. Odobrio				
				ZAJEDNICA MAŠINSKIH ŠKOLA		Oznaka	List	
						PT.00.06		
St.i	Izmene	Datum	Ime			Izv.pod.	Zamena za	

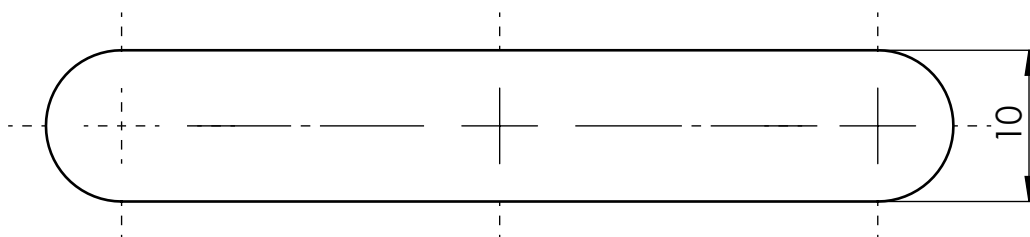
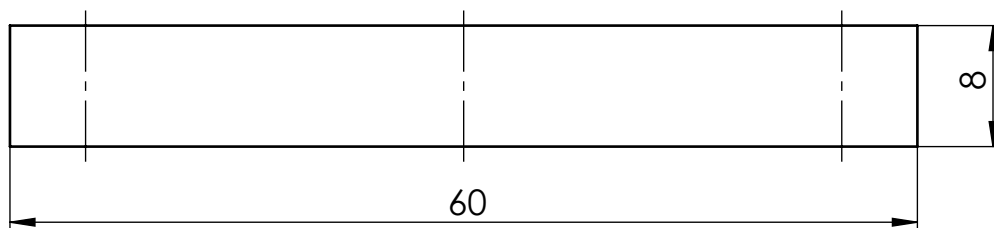

Tolerancije slobodnih mera		Površinska hrapavost		Površinska zaštita		
Materijal				Termička obrada		
		Broj komada 1		Format A4	Masa	
				Razmera 2:1		
			Datum	Naziv Klin 10x8x60		
			Obradio			
			Stand.			
			Odobrio			
			ZAJEDNICA MAŠINSKIH ŠKOLA		Oznaka	List
					PT.00.07	
St.i	Izmene	Datum			Ime	Izv.pod.

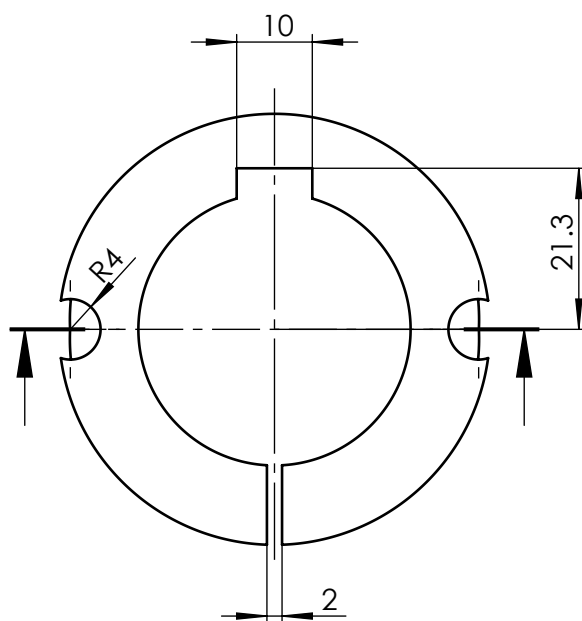
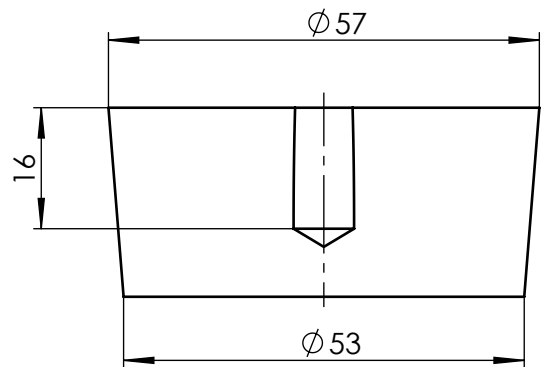
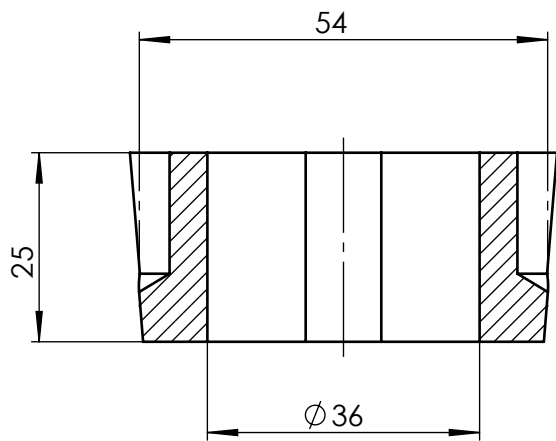

Tolerancije slobodnih mera		Površinska hrapavost		Površinska zaštita		
Materijal				Termička obrada		
		Broj komada 2		Format A4	Masa	
				Razmera 1:1		
				Datum		
				Obradio		
				Stand.		
				Odobrio		
				ZAJEDNICA MAŠINSKIH ŠKOLA		
Naziv		Oznaka				List
Konusna čaura		PT.00.08				
St.i	Izmene	Datum	Ime	Izv.pod.	Zamena za	

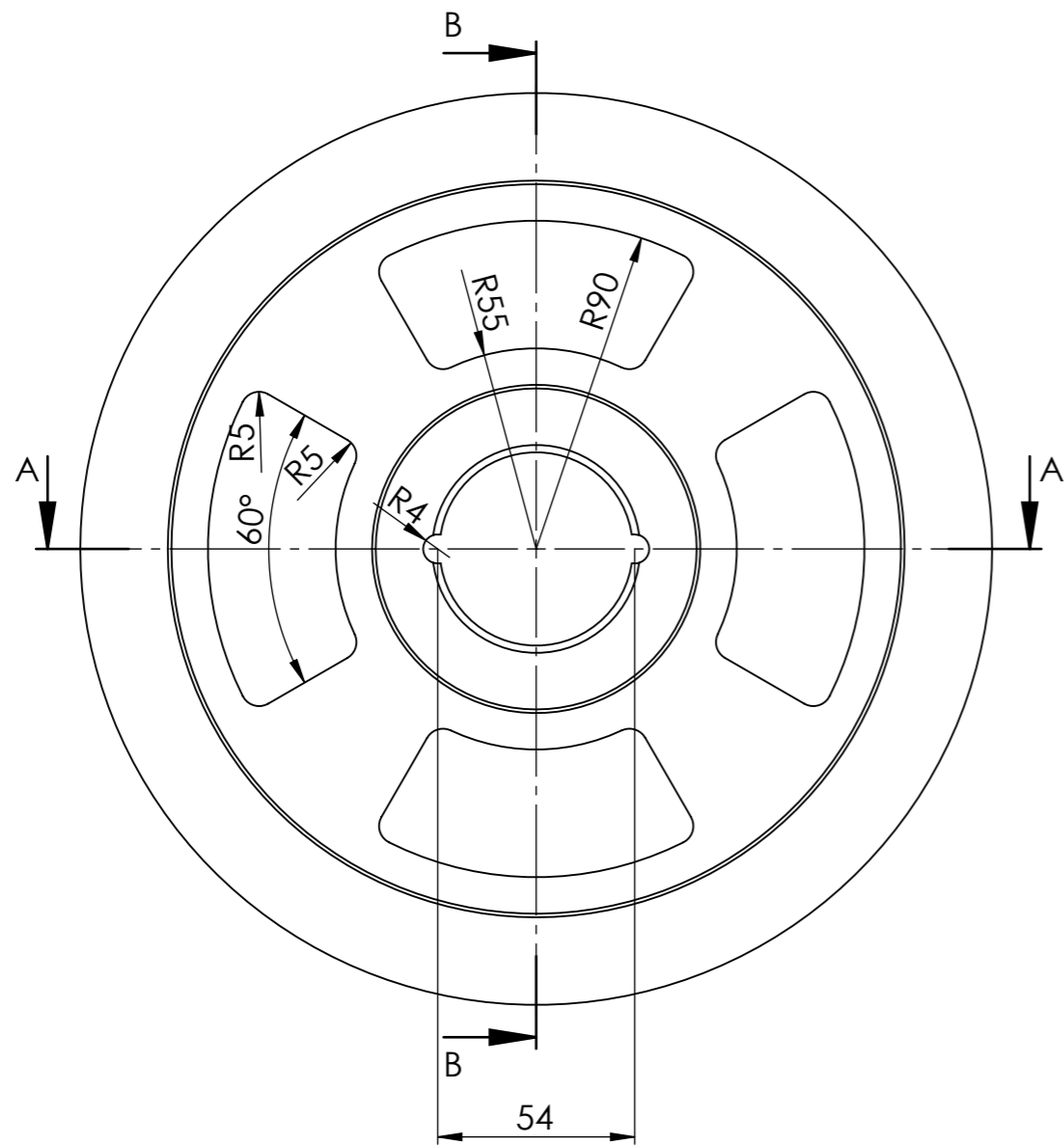
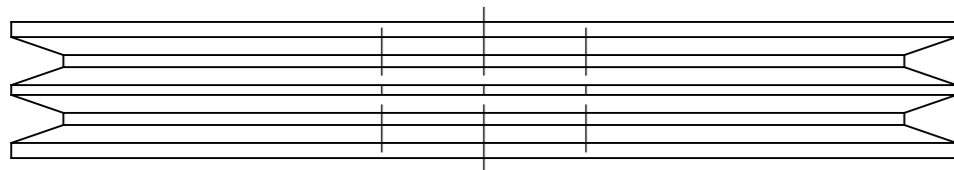

Presek A-A

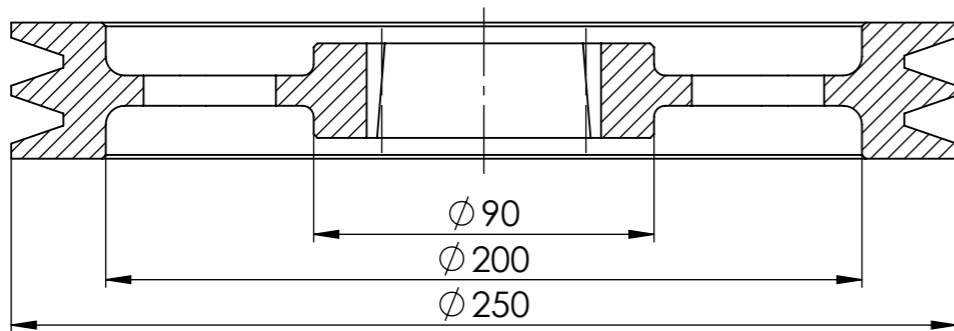

Presek B-B

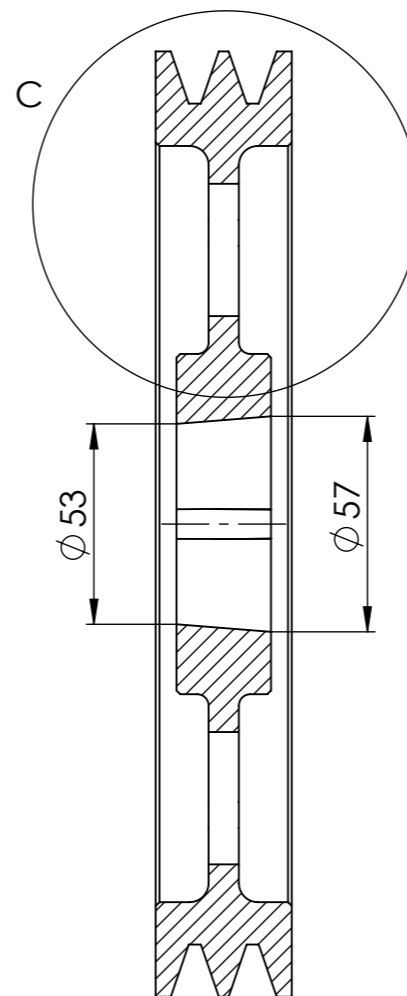

Detalj C
Razmera 1 : 1

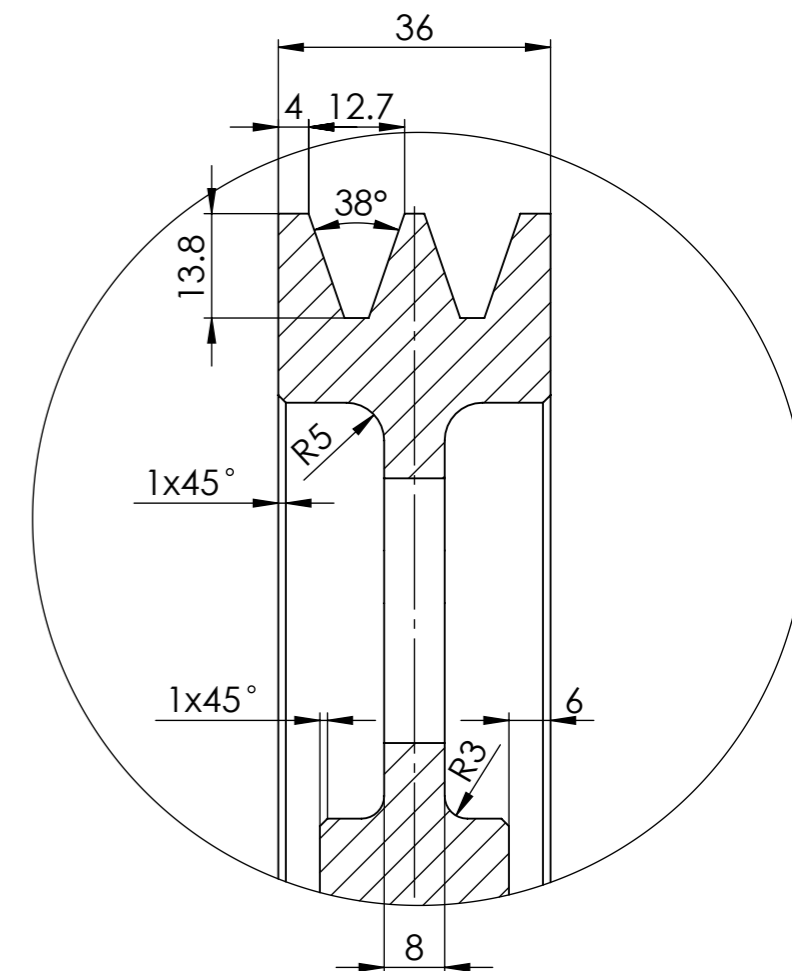

		Broj komada	1		Format	A3	Masa		Razmera	1:2
				Datum		Naziv Remenica				
				Obradio						
				Stand. Odobrio						
ZAJEDNICA MAŠINSKIH ŠKOLA					Oznaka	PT.00.09			List	
					Izv.pod.	Zamena za				
St.i	Izmene	Datum	Ime							

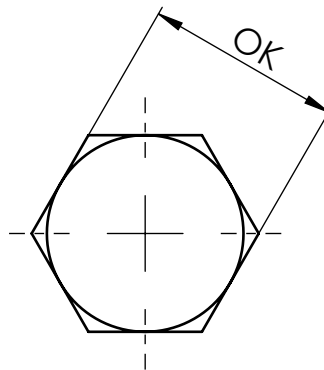
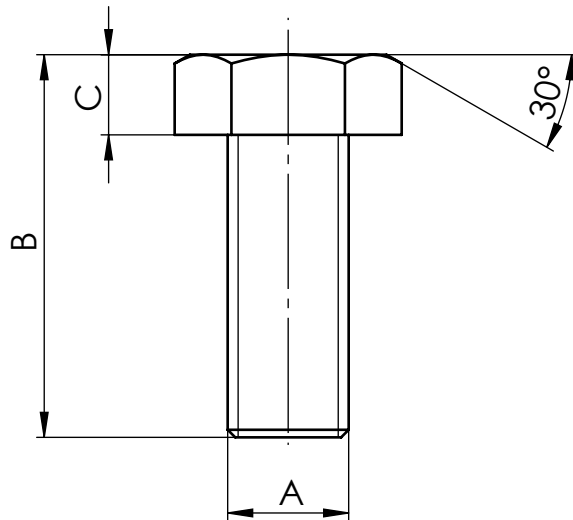

	OK	A	B	C
Poz. 10	13	M8	25.3	5.3
Poz. 11	17	M10	41.4	6.4
Poz. 12	24	M16	50	10

Tolerancije slobodnih mera		Površinska hrapavost		Površinska zaštita	
Materijal				Termička obrada	
		Broj komada 10 x M8, 28 x M10, 4 x M16		Format A4	Razmera 2:1
Datum				Naziv Zavrtanj M8x20 Zavrtanj M10x35 Zavrtanj M16x40	
Obradio					
Stand.					
Odobrio					
ZAJEDNICA MAŠINSKIH ŠKOLA				Oznaka	PT.00.10 PT.00.11 PT.00.12
				List	
				Izv.pod.	Zamena za
St.i	Izmene	Datum	Ime		

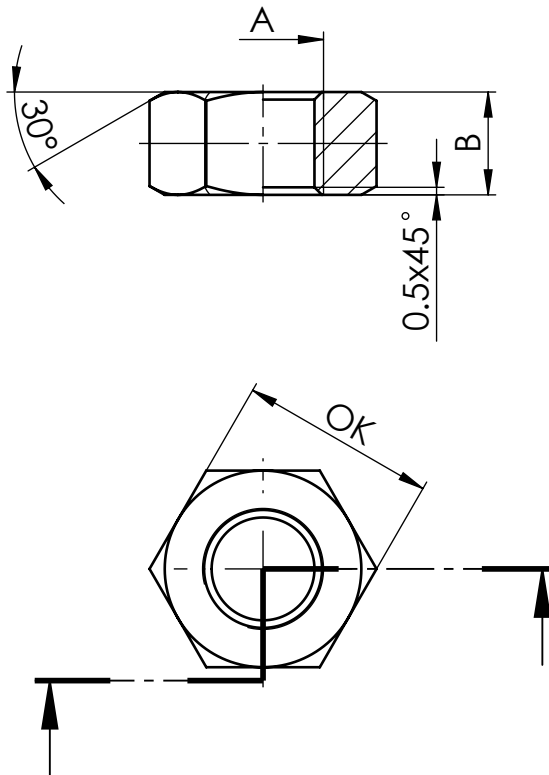

	OK	A	B
Poz. 13	13	M8	6.8
Poz. 14	17	M10	8.4
Poz. 15	24	M16	13

Tolerancije slobodnih mera		Površinska hrapavost		Površinska zaštita		
Materijal				Termička obrada		
		Broj komada 10 x M8, 28 x M10, 4 x M16		Format A4	Razmera 2:1	
Datum				Naziv Navrtka M8 Navrtka M10 Navrtka M16		
Obradio						
Stand.						
Odobrio						
ZAJEDNICA MAŠINSKIH ŠKOLA				Oznaka PT.00.13	List	
				PT.00.14		
St.i		Izmene	Datum	Ime	Izv.pod.	Zamena za
				PT.00.15		